

Furon[®] HPVM Valve

Pneumatically Actuated, 2-Way Valve (3/16" & 1/4" Orifice)

Description

Pneumatically actuated, 2-way diaphragm valve for reliable on/off control.

Furon[®] HPVM Valves are compact and robust, offering superior performance and reliability in applications involving aggressive chemistries or abrasive slurries. Featuring a compact footprint with common port height among all configurations, Furon[®] HPVM Valves allow for ease of installation and optimum use of precious space. Additionally, Furon[®] HPVM valves feature flow paths specially designed to minimize entrapment of liquids within the valve.

Applications

Furon[®] HPVM Valves are ideal for use in the semiconductor industry, or other applications requiring high purity and/or superior chemical resistance.

- Designed for use in ultrapure deionized water and aggressive chemical applications
- Suitable for use in abrasive slurry
- Market applications include Semiconductor, Flat Panel, Photovoltaic, and Chemical Processing



Features and Benefits

- Pressure rated to 80 PSIG (5.5 bar)
- Visual position indicator with option for fiber-optic sensor
- Integral mounting base with top or bottom mount standard
- High purity PFA injection molded body with PTFE diaphragm
- Common port height among all HPVM configurations simplifies installation
- HPVM valve designs have been successfully tested for more than 1 million cycles

ASK AN ENGINEER

Furon HPVM-Valve

Part Number	Flow Path	End Connection	Orifice (in.)	Port Size (in.)	A
HPVM2-744-NC	Normally Closed	FuseBond™	1/4	1/4	1.6 (42.2 mm)
HPVM2-F34-NC	Normally Closed	FlareGrip® II	3/16	1/4	3.5 (89.9 mm)
HPVM2-F46-NC	Normally Closed	FlareGrip	1/4	3/8	3.7 (95.3 mm)
HPVM2-S30044-NC	Normally Closed	Super 300®	1/4	1/4	4.2 (102.2 mm)
HPVM2-S30046-NC	Normally Closed	Super 300	1/4	3/8	4.4 (113.3 mm)
HPVM2-744-NO	Normally Open	FuseBond	1/4	1/4	1.6 (42.2 mm)
HPVM2-F34-NO	Normally Open	FlareGrip II	3/16	1/4	3.5 (89.9 mm)
HPVM2-F46-NO	Normally Open	FlareGrip II	1/4	3/8	3.7 (95.3 mm)
HPVM2-S30044-NO	Normally Open	Super 300	1/4	1/4	4.2 (102.2 mm)
HPVM2-S30046-NO	Normally Open	Super 300	1/4	3/8	4.4 (113.3 mm)

Ordering Specifications

Operating Pressure	80 psig (5.5 bar)
Back Pressure	80 psig (5.5 bar)
Flow	C _v 0.70
Operating Temperature	203°F (95°C)
Actuator Pressure	60 - 100 PSIG (4.1 - 6.9 bar)
Body	PFA or PTFE
Diaphragm	PTFE
Actuator Housing	Polypropylene

HCl more than 2.1 million cycles
HF more than 2.1 million cycles
Slurry more than 1.6 million cycles

Standard Options

- PFA Flare nuts (add-3)
- Other end connection types available:
 - FNPT
 - Pipe
 - Tube End
- Fiber optic position sensor
- Stainless steel actuation port insert (#10-32)
- DI Micro-adjust bypass
- Stroke limiter
- Custom manifolds

Please consult factory for further details >>

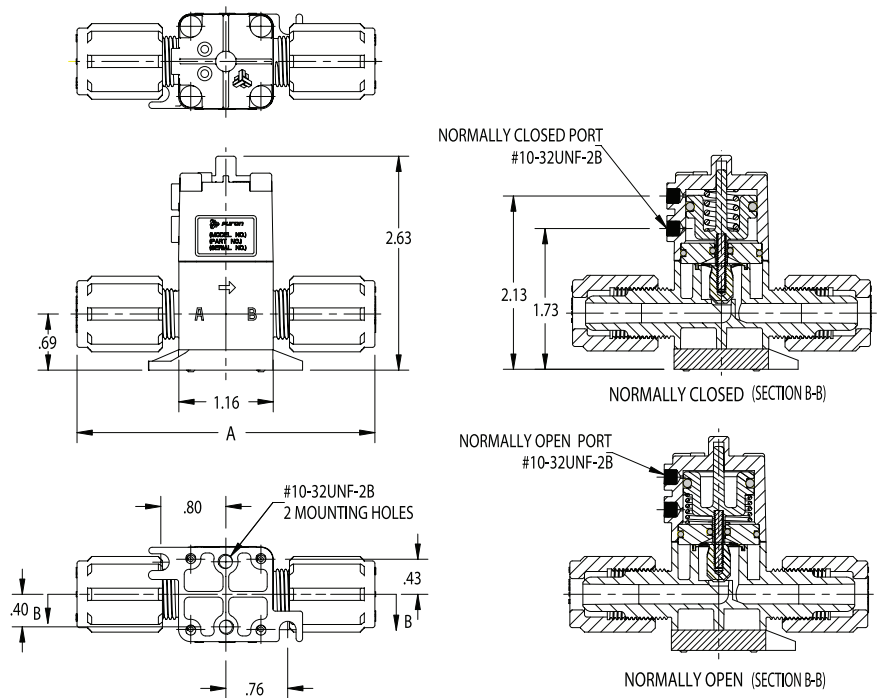
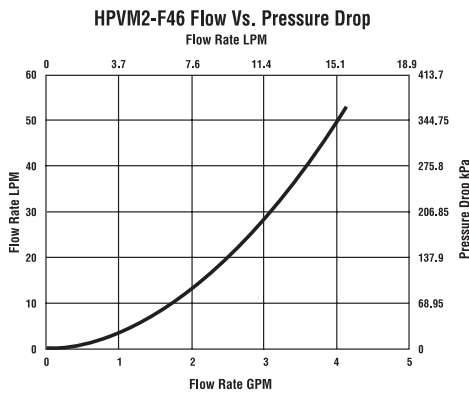

Saint-Gobain Performance Plastics
 7301 Orangewood Avenue
 Garden Grove, CA 92841
 1-800-833-5661
 Tel: (714) 630-5818
 Fax: (714) 688-2614

www.processsystems.saint-gobain.com

NOTE: The data and details given in this document are correct and up to date. This document is intended to provide information about the product and possible applications. This document is not the product specification and does not provide specific features, nor does it guarantee product performance in specific applications. Saint-Gobain cannot anticipate or control the conditions of the field and for this reason strongly recommends that practical tests are conducted to ensure that the product meets the requirements of a specific application.

Furon®, FlareGrip® and FuseBond™ are registered trademarks of Saint-Gobain Performance Plastics. Super 300® is a registered trademark of Nippon Pillar Packaging Co. LTD.

IMPORTANT: It is the user's responsibility to ensure the suitability and safety of Saint-Gobain Performance Plastics products for all intended uses and that the components to be used comply with all applicable regulatory requirements. Saint-Gobain Performance Plastics assumes no responsibility for any product failures that occur due to misuse arising out of the design, fabrication or application of the products into which they are incorporated.

WARRANTY: For a period of 12 months from the date of first sale, Saint-Gobain Performance Plastics warrants this product to be free of defects in materials and workmanship. The only obligation under any applicable product warranty will be to replace any portion proving defective, or at our option, to refund the purchase price thereof. THIS IS THE EXCLUSIVE WARRANTY AND IS EXPRESSLY IN LIEU OF ANY AND ALL OTHER OBLIGATIONS, GUARANTEES, WARRANTIES AND REPRESENTATIONS. SAINT-GOBAIN PERFORMANCE PLASTICS DISCLAIMS ALL IMPLIED WARRANTIES OF MERCHANTABILITY AND FITNESS FOR A PARTICULAR PURPOSE.